

RCW

Concrete Mixer Chute Wash Water Treatment



The Unit

Designed specifically for treating wash water and solids generated from washing mixer truck chutes. Siltbuster's RCW (Roadside Concrete Washout) Unit provides a compact, rapidly deployable method of dealing with concrete wash water.

Recognised and adopted by many contractors as best practice, a single RCW can handle up to 30 washouts spread over a working day ensuring your site remains compliant with the Environment Agency Regulatory Position Statement (guidelines).

The RCW can either run via 110V mains supply or off an integrated 12V battery, allowing operation in the most remote locations!

How it Works

- High pH (12-13) wash water is discharged from the concrete mixer trucks chutes being washed directly into the reception hoppers
- The aggregate and cement fines are retained in the geotextile dewatering bags and allowed to hydrate whilst the water bleeds into the main storage chamber
- A battery powered, automated digital pH controller monitors the pH and automatically doses Carbon Dioxide (CO₂) to reduce the pH when an alkaline value is detected
- Once the precipitated fines are left to settle, the treated water with a pH of between 6 - 9 is manually discharged via a control valve for safe disposal or reuse on site

Did you know...

The pH scale is Logarithmic?

That is why if you were to try and dilute 1L of pH 12 wash water to return it to pH 7, it would take 100,000L of tap water to dilute it!

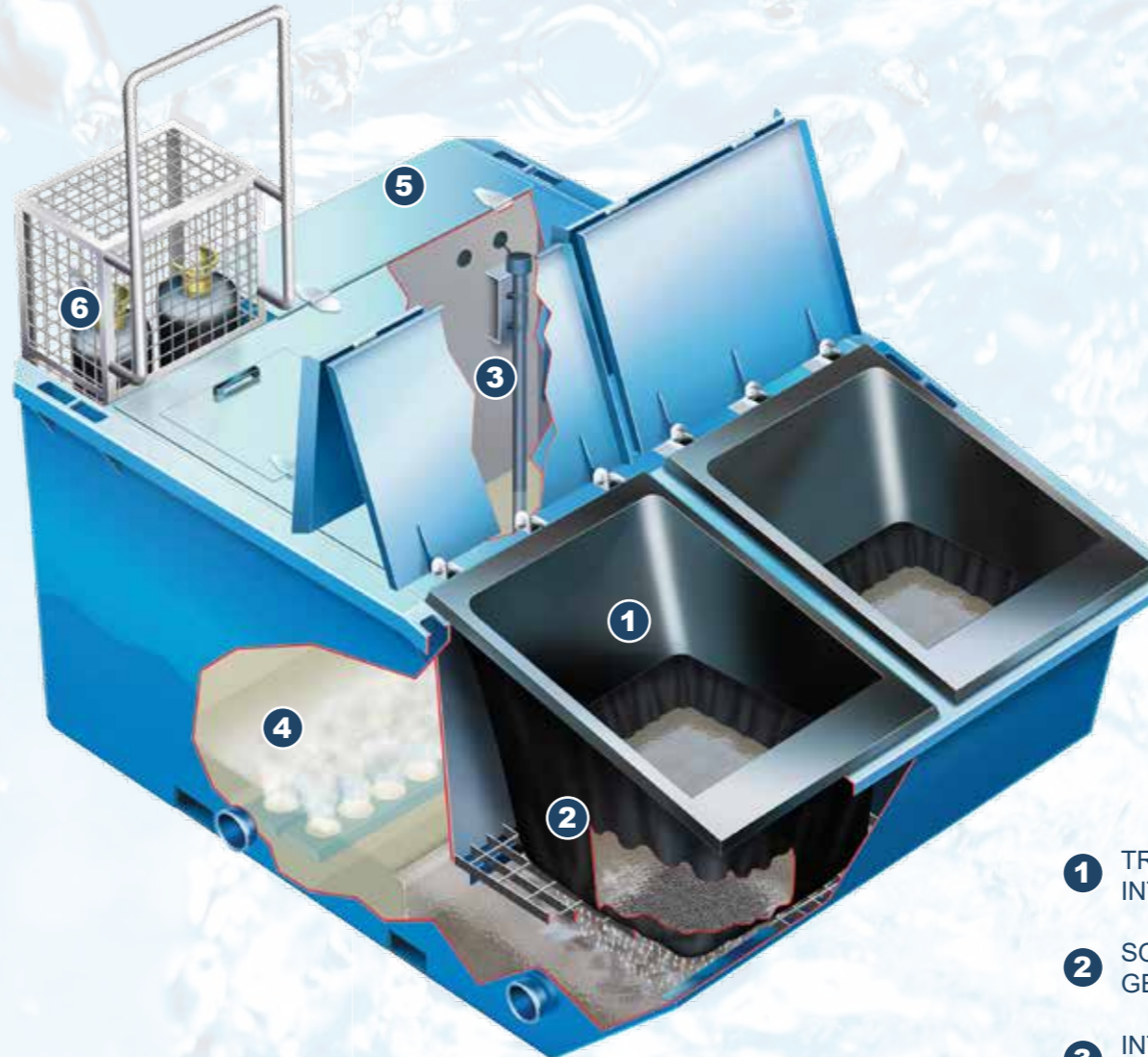

KEY ADVANTAGES

- + Self contained system - Ready to Run
- + Runs off built in 12V battery for 2000 hours
- + Readily transportable, fast and simple to deploy, easy to operate, low maintenance
- + Optional data logger (see ancillaries list)

TYPICAL APPLICATIONS

- + Remote sites without power or water
- + Medium to large concrete pours
- + Sites needing a compact wash out solution
- + Wind farms, industrial buildings, civils infrastructure projects

- 1 TRUCKS WASH OUT INTO HOPPERS
- 2 SOLIDS RETAINED IN GEOTEXTILE BAGS
- 3 INTEGRATED pH PROBE
- 4 MICROFINE CO₂ DIFFUSERS
- 5 RUNS OFF BUILT IN 12V BATTERY
- 6 DUTY AND STANDBY CO₂ CYLINDERS

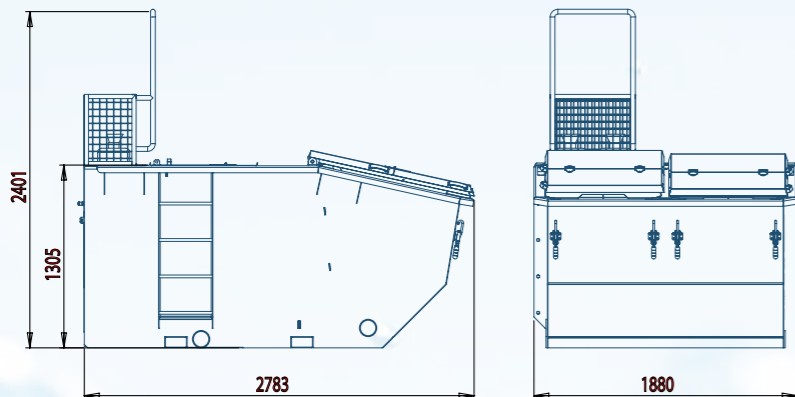

RCW Data Sheet	
Length:	2.8 m
Width:	1.9 m
Height:	2.5 m
Empty Weight:	1,200 kg
Capacity:	30 Trucks/Day
Outlet Size:	2" M Bauer
Power Req:	Inc. Battery



For Hire, Sales & Technical Support call Siltbuster® on 01600 772256